

IBS Intelligent Battery System
the ultimate Battery System

IBS-DBR Dual Battery Relay

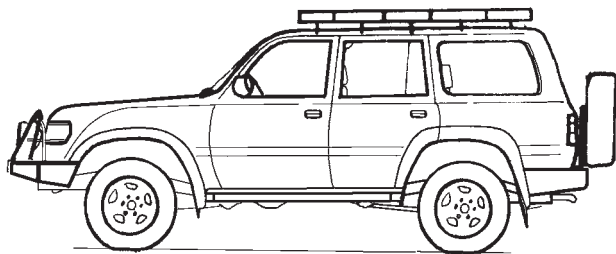

Installation

Dual Battery Relay

Green LED

Red LED



Terminals:

30	+Battery Aux (12V)
87	+Battery Main (12V)
85	-Battery GND
86	Manual Link (to GND)

DBR open with control board

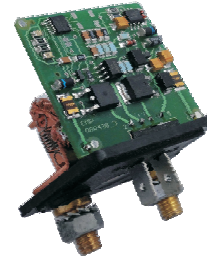

Terminal Configuration

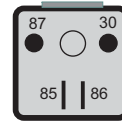

IBS-DBR

Wiring

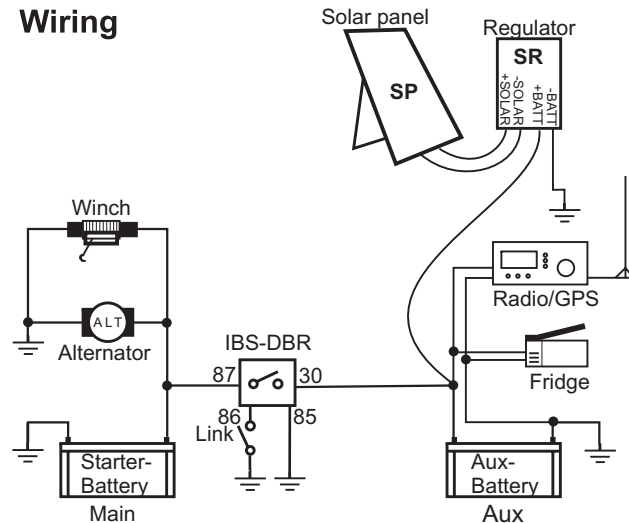

Optional Solar System

Users Manual

The IBS-DBR is an ultra compact microcomputer controlled high performance Dual Battery Relay offering 200Amp continuous and 500Amp inrush current capability. The DBR offers the latest inbuilt IBS-RBM (Relay Booster Module) feature to perform a link start from auxiliary battery (activated with an external switch to GND) if the starter battery has failed. Easy to understand LEDs indicate all possible functions. Due to its easy setup the DBR is simple to be installed. In combination with IBS or DBI-DBS very powerful multi battery systems can be configured. The built in trailer battery recognition detects if a battery is present, otherwise it disengages the link function.

LED Status indication

Green LED

- ☀️ Flashing: DBR operational
- On: Batteries linked
- Off: Batteries not connected

Red LED

- Off: Everything OK
- On: Batteries manually linked by external switch
- ☀️ 1xFlashing: Battery Main or Aux is low
- ☀️☀️ 2xFlashing: Relay defective
- ☀️☀️☀️ 3xFlashing: Main battery missing
- ☀️☀️☀️☀️ 4xFlashing: Aux battery missing

•Bi-directional Automatic Battery Link

While the engine is running the Main and Aux batteries are linked together for parallel charging from the alternator (green LED is on). If the engine is stopped, the two batteries will be disconnected automatically with some delay (depending battery status) and the green LED starts flashing. Appliances as fridges, lights, compressors, inverters are now safely fed from the Aux battery. Extra charge on Aux battery (Solar) is detected and batteries are linked (green LED is on).

•Manual Battery Link

In an emergency situation (defective or empty Main Battery) or in case of higher power consumption the two batteries (Main & Aux) may be linked together by activating the external link switch for 30 Min.(red LED is on). After the 30 Min. the system returns to the automatic mode. During this 30 Min a new activation of the external switch starts again the 30 Min. time delay. The Load Sharing Function with the manual battery link reduces the stress on alternator, wiring and the batteries in conjunction with the use of electrical winches.

•Winch application

Connect an electrical recovery winch to the main battery as shown in the wiring diagram.

Installation Instructions

Use adequate wires (25mm²) for the heavy duty wiring from the batteries (+) to the IBS 200A relay (87/30 terminals), install a by-pass wire (25mm²) between Main Battery Minus (Starter) and Aux Battery Minus to increase winching performance.

Check the correct wiring of the relay. Terminal 87 goes to Main and 30 to Aux battery plus as shown in the wiring diagram! The relay is hot in normal application to keep the contacts securely closed.

There is no special installation order how the 3 connections have to be made. We recommend first to connect the GND connection and finally the 2 power wires.

The external link input can be left open or equipped with a switch to GND. Every link action making contact to GND triggers the 30 Min. manual link function. The DBR only triggers with the dynamic action of this switch. If the switch stays linked (on position) the DBR still deactivates the manual link function after 30 Min and waits for the next off/on activation of the link switch.

The installation into a Toyota LandCruiser HDJ80 (version Europe) requires special instructions. Please contact IBS or your local dealer.

Warranty:
This warranty shall not apply to any product which has been subject to any misuse, negligence, accident or has been used (or opened, broken seal) for any other purpose than was designed.

5 year: Installation done by an IBS **approved** auto electrician.
2 year: Other installations.



Seestrasse 24
3600 Thun / Switzerland
Ph./Fax: +41 (0)33 221 06 16/17
www.ibs-tech.ch
www.ibs-dual-battery.ch
www.ibs-inverters.ch

MADE IN SWITZERLAND

Distributor:

IBS_DBR_12V_e_1 / 5.1.2010 SW V2.1

Applications

General Functions

This Dual Battery Relay has been designed for Dual Battery Systems. The Batteries are automatically linked for charging and isolated when discharging. In emergency situations a manual override function to link the batteries can be actuated. The DBR is equipped with an automatic trailer link de-activation in case no trailer is present. In this case no power is supplied to the trailer plug. Function is active after trailer is disconnected and car restarted.

Dual battery in car or trailer

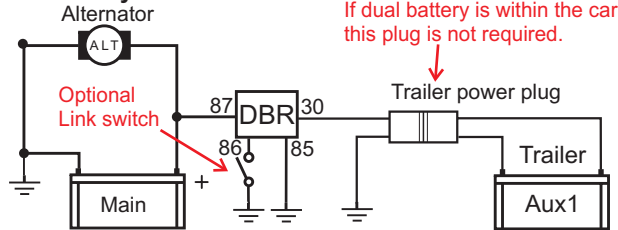

DBR integration into an existing IBS Dual Battery System

The DBR is useful to extend an existing IBS-DBS or DBI-DBS Dual Battery System to achieve a triple battery system. It is possible to split the green control wire from the dual battery system and make also a connection to the terminal 86 on DBR. Every time the monitor activates the IBS Relay the manual link function of the DBR is also activated for 30 Min. In Emergencies if on the IBS Monitor the Link button is pressed for a link start from Aux1 also Aux2 is linked in for 30 Min. If one of the 3 batteries is equipped with a solar system, sooner or later all batteries are automatically going to achieve this solar charge due to the bi-directional automatic link function of all IBS systems.

Triple battery in car or trailer

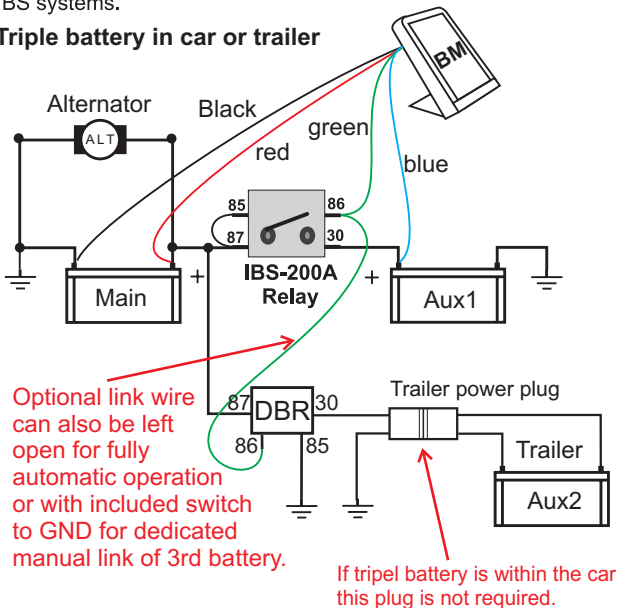

Specifications

System Setup Architecture	MicroComputer RISK MicroPower Interrupt based
Supply Voltage	4..16V
System Voltage	12V
Measuring Range (sense wire blue)	4..16V
Linking threshold starter battery (link/sep)	13.1V/13.0V
Linking threshold Aux battery (link/sep)	13.3V/13.0V
Accuracy	+/-1%
Consumption stand-by	<5mA
RBM activation level	U _{min} <10V

Status indication Green LED:

Flashing	System activ
On	Batteries linked
Off	System not connected

Status indication Red LED:

One flash	Low Batt main or Aux
Two flashes	Relay defective
Three flashes	Main Battery missing
Four flashes	Aux Battery missing
On	Batteries manually linked
Off	Everything Ok

Relay Consumption on-state	0.6A
Relay Max/Continuous load/inrush current	200A/500A
Relay contact material	silver
Relay Booster Module (RBM)	included

Starter and Gel batteries may be combined yes

Operating Temperature	-40°..+125° C
Housing	ABS black IP40
Size	100x65x24 [mm]
Protection level	IP67(sealed)

Terminals:

30:	+ Battery Aux
87:	+ Battery Main
85:	- Battery GND
86:	Manual Link



RoHS OK

Protection:

- against wrong polarity
- Main battery failure (RBM)